

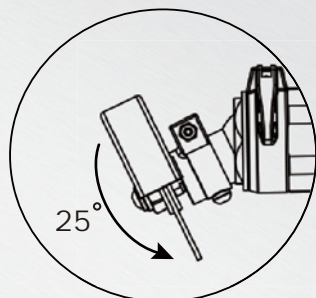

## Flexible Head Cut-off Tool

- **3-Stage Flexible head** - user friendly
- **Built-in Speed Regulator**
- **Reversible Switch** - direct sparks away for safety
- **0.75 HP High Power, Low-noise and Swivel exhaust**

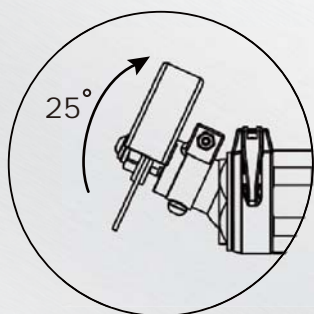

### Flexible Head

3-Stage

- 25° up
- straight
- 25° down

**New**

### Flexible Head adjustment

click lever

**Reversible Switch**  
direct sparks away



**360° Swivel exhaust**

**Speed Regulator**

Item No.	Speed RPM	Power KW/HP	Wheel mm/inch	Reversible or not	Length mm/inch	Weight kg/lb	Air Inlet inch	Air Consumption LPM / CFM	Noise Level	Working Pressure Bar / PSI
81204	16,000	0.56 (0.75)	75 (3)	V	249 (9.8)	1.1 (2.4)	1/4	102 (3.6)	88 DB	6.2 (90)

## Low Vibration Air Hammer



- **Damping system** creates highly efficient hammer beating
- **Active Air Spring** absorb operation shock
- **Extremely Low Vibration** avoiding work fatigue
- **Quick-Change Retainer Chuck**

**New**

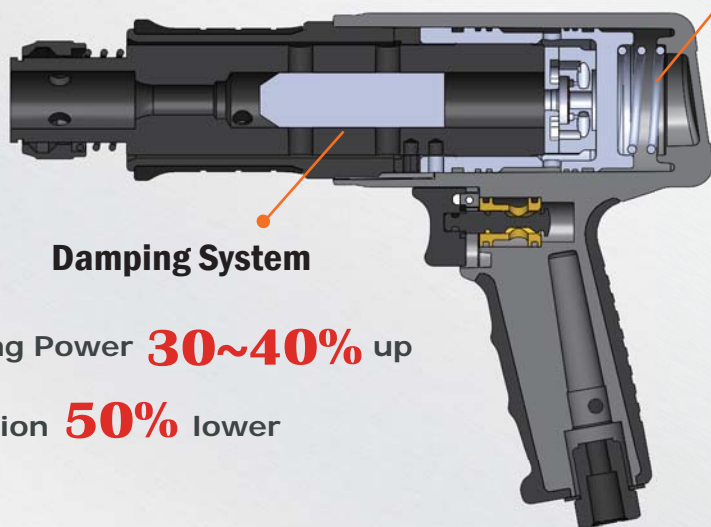

**Damping System**

**Active Air Spring**

Beating Power **30~40%** up

Vibration **50%** lower



Barrel / Beating Power

- 41203** 150mm / 460 kgf
- 41204** 190mm / 850 kgf
- 41206** 250mm / 1085 kgf

Item No.	Speed BPM	Stroke mm/inch	Shank (inch) Round	Piston D. mm/inch	Length mm/inch	Weight kg/lb	Air Consumption LPM / CFM	Air Inlet inch	Vibration m/s <sup>2</sup>	Noise Level LpA / LwA
41203	4,000	30.1 (1.2)	0.41	19 (0.75)	200 (7.9)	1.8 (3.9)	102 (3.6)	1/4	2.7	96 DB
41204	3,500	58.0 (2.3)	0.41	19 (0.75)	242 (9.5)	2.2 (4.9)	96 (3.4)	1/4	3.6	88 DB
41206	2,500	89.0 (3.5)	0.41	19 (0.75)	290 (11.4)	2.5 (5.5)	88 (3.1)	1/4	4.2	96 DB